



## JENar<sup>®</sup> 255-1064-239

F-Theta lens for larger beam diameters and scan fields



The precision and reliability requirements in laser material processing are becoming more and more demanding. Reap the benefits of Jenoptik's development know-how and proven technologies in the production of optical components, lenses and modules for laser material processing.

Jenoptik's newly developed F-Theta lens JENar<sup>®</sup> for 1064 nm is designed and optimized for large beam diameters of up to 20 mm (for  $1/e^2$  truncated Gaussian beam). So by the established focal length of 255 mm the lens obtains a spot size of 24  $\mu\text{m}$ . The scan field size can be enlarged up to a diameter of 239 mm without vignetting. The lens is corrected to avoid focused back reflections within the lens and close to the recommended galvo mirror positions.

Against the background of steadily rising laser power the lenses are manufactured out of high-resistant materials to minimize lens damages.

In order to support our customers, we also provide STEP files on request. This enables a quick and comfortable mechanical integration of the F-Theta lens JENar<sup>®</sup> in any systems.

# F-Theta lens JENar<sup>®</sup> 255-1064-239

## Specifications

Focal length:	255 mm
Wavelength:	1064 nm
Scan field Ø:	239 mm
Diagonal scan angle:	53.2°
Back working distance:	291 mm
Flange focus distance:	336 mm
Entrance pupil Ø:	30 mm
Input beam Ø 1/e <sup>2</sup> :	20 mm
Focus size Ø 1/e <sup>2</sup> :	24 µm
a1	25 mm
a2	39 mm
Telecentricity:	15°
Weight:	1.4 kg
Order number:	017700-017-26

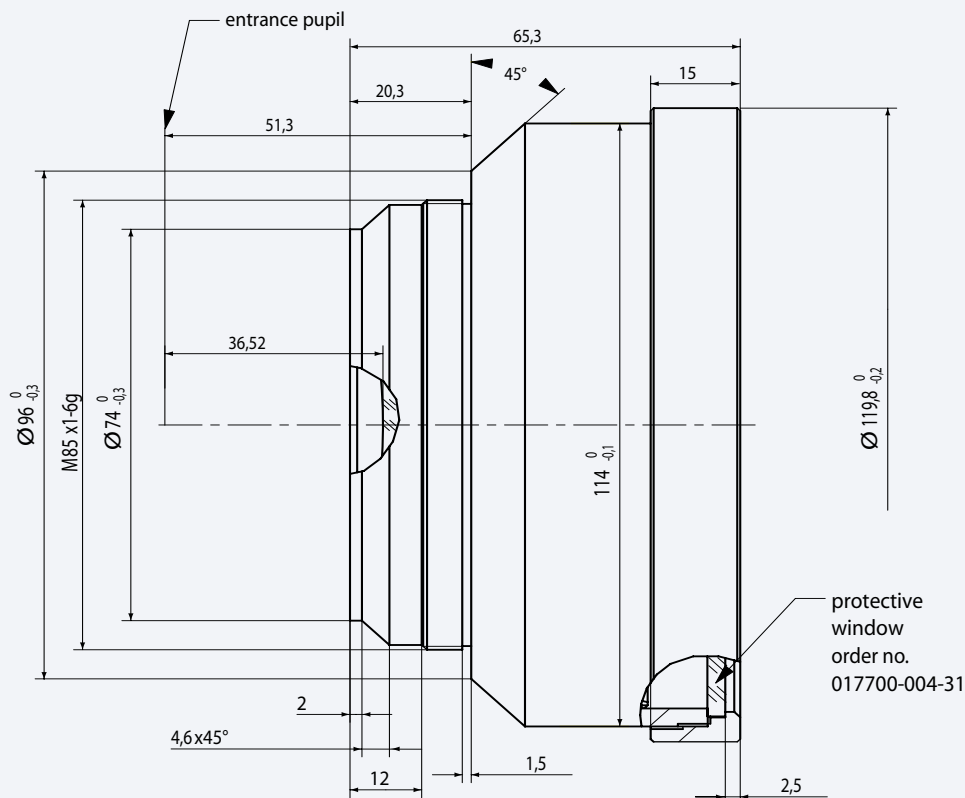
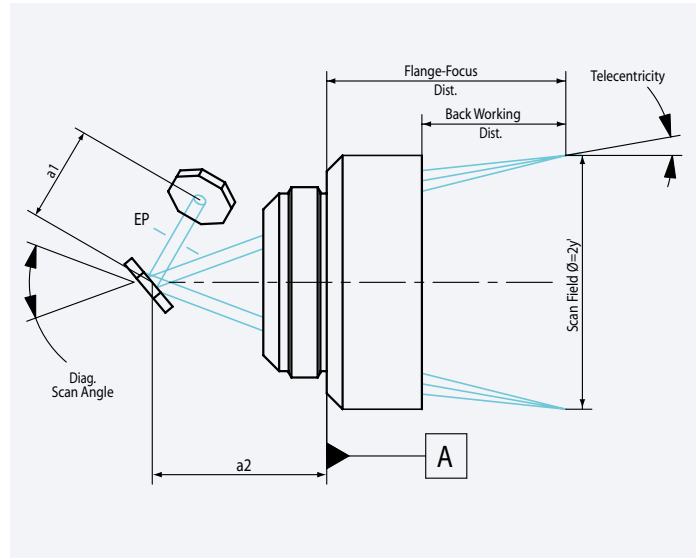

It is our policy to constantly improve the design and specifications. Accordingly, the details represented herein cannot be regarded as final and binding.



JENOPTIK | Optical Systems  
 Optics Business Unit  
 JENOPTIK Laser, Optik, Systeme GmbH  
 Goeschwitzer Strasse 25 | 07745 Jena | Germany  
 Phone +49 3641 65-3148 | Fax -3677  
 optics@jenoptik.com | www.jenoptik-los.com

Coastal Optical Systems, Inc.  
 16490 Innovation Drive | Jupiter | FL 33478 | USA  
 Phone +1 256 859-1886 | Fax +1 256 859-5890  
 sales@coastalopt.com | www.coastalopt.com